

Saramonic

**Modular Full-Duplex Wireless
Intercom System**
模块化全双工无线对讲系统

WiTalk9 X

Statement

Read this manual carefully before use and follow all instructions for operation and storage. Retain this manual for future reference. For further assistance, contact your retailer or email support@saramonic.com

Safety Statement and Cautions

1. Please read this manual carefully before use and follow the instructions for operation, storage, and charging. Keep this manual for future reference.
2. Do not disassemble the headset, charging case, battery, or any internal component. Unauthorized disassembly may cause damage and void the warranty.
3. This product is not designed for prolonged exposure to water or heavy dust. Do not immerse it in water or use it for extended periods in highly humid, dusty, or corrosive environments.
4. Prolonged listening at high volume may cause hearing damage. Adjust the volume to an appropriate level for the operating environment.
5. For optimal voice pickup, position the microphone approximately 2 cm from the corner of the mouth and avoid placing it too close to the lips to reduce plosives and breath noise.
6. Use only the supplied battery and approved charging equipment. Do not crush, puncture, disassemble, or expose the battery to fire.

Product Overview

WiTalk9 X is a lightweight full-duplex wireless intercom system designed for professional team communication in film production, live events, stage operation, content creation, and other workflows that require real-time coordination.

Operating on 1.9 GHz DECT technology, the system supports a line-of-sight transmission range of up to 400 m. Actual performance may vary depending on the operating environment, physical obstructions, and regional version.

WiTalk9 X features a modular headset design that supports single-ear, dual-ear, and helmet-style dual-ear configurations according to different roles and use scenarios. Some configurations may require optional accessories.

This manual uses the WiTalk9 X-3S three-person package as the primary reference. Other packages in the same series follow the same core operating logic, while the exact package contents depend on the specific SKU.

Features

1. Modular Design

Supports quick switching between single-ear, dual-ear, and helmet-mounted configurations to adapt to different roles and operational requirements.

2. Dual-Mode AI Noise Reduction

Equipped with a dual-microphone array. Provides Natural Mode (noise reduction off) for quiet environments and Noise Reduction Mode for dynamic background noise suppression in noisy environments.

3. Full System Compatibility

Supports independent master-remote networking and integration with WiTalk9 systems and WiTalk BASE stations for hybrid networking and large-scale command and dispatch operations.

4. Lightweight & Comfortable

The single-ear headset weighs approximately 172 g (including battery). The ergonomic design supports extended wear.

5. Extended Battery Life

Removable lithium battery design provides over 12 hours of operation for remote headsets and supports quick battery replacement.

Optional Package

1. The WiTalk9 X is available in multiple package configurations to accommodate different team sizes. This manual applies to all configurations. Package contents may include the following items:

- | | |
|---|--|
| ① Single-ear Master Headset (Orange silicone headband) | ⑪ Battery (1000 mAh) |
| ② Single-ear Remote Headset (Black silicone headband) | ⑫ 10-slot Charging Case |
| ③ Dual-ear Master Headset (Orange silicone headband) | ⑬ 2.5 mm to 3.5 mm L-shaped Adapter |
| ④ Dual-ear Remote Headset (Black silicone headband) | ⑭ Phillips Screwdriver |
| ⑤ Helmet-style Dual-ear Master Headset (Orange silicone headband) | ⑮ User Manual |
| ⑥ Helmet-style Dual-ear Remote Headset (Black silicone headband) | ⑯ Warranty Card |
| ⑦ Over-ear Earpad | ⑰ Operation Guide / APP Download QR Code |
| ⑧ On-ear Foam Cushion | ⑱ Portable Storage Case |
| ⑨ Disposable On-ear Cover | |
| ⑩ Headband Cushion Foam | |

2. The WiTalk9 X-3S (three-person, single-ear) package is shown as an example. Contents may vary by configuration.

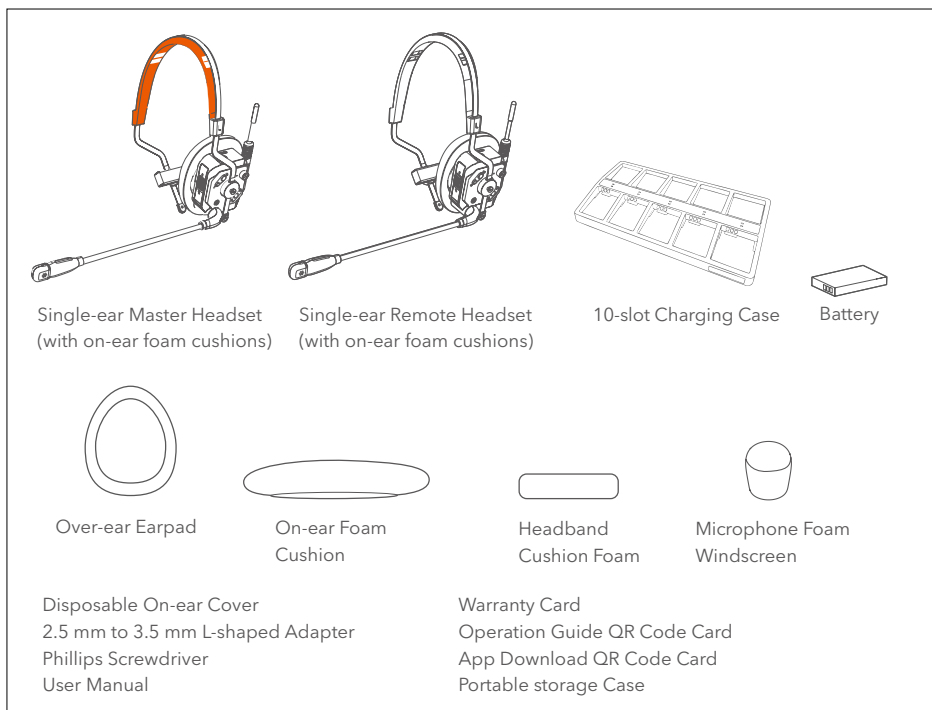

Notes

1. Additional remote headsets can be purchased and paired with the master headset to expand the system beyond the 3S package.
2. Package options include single-ear, dual-ear, and helmet-mounted dual-ear headsets to suit different application scenarios.
3. Optional dual-ear headband and helmet mounting bracket accessories are available, allowing a single-ear headset to be converted through modular replacement.

Product Overview

Master & Remote Headset

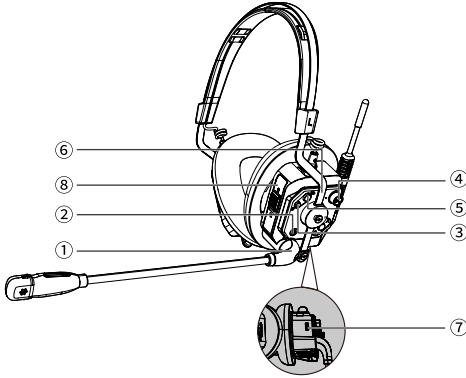

① Microphone Boom: Supports 270° rotation. Flip up to mute; Fold down to talk.

② Microphone Array: Includes a primary microphone for voice pickup and a secondary microphone for environmental noise reduction.

③ Power / Pairing Button:

Press and hold for 2 seconds to power on or off.

Press and hold for 5 seconds (when powered off) to enter pairing mode.

④ Volume Knob/Function Button:

Rotate: Adjusts volume.

Press and hold:

Master headset: Enables Announce mode; release to mute.

Remote headset: Enables PTT (push-to-talk); release to mute.

⑤ Mute Button: Physical mute control (in addition to boom mute).

Short press to mute or unmute the microphone.

⑥ Headband Adjustment Section: Adjusts the headband for a comfortable fit.

⑦ USB-C Port: For charging, firmware updates, and connection to the base station.

⑧ Battery Compartment: Supports quick-release battery replacement

Indicator Light Description

Power Status Indicator

Status	Indicator	Meaning
Unpaired	Blinking blue (slow)	Searching for headsets or base stations
Successfully paired	Solid Blue	Normal communication active

Mute	Solid Red	Microphone muted (audio can be heard, not transmitted)
Pairing mode	Blinking blue (fast)	Pairing in Progress
Low battery	Blinking Red	Battery level low; recharge or replace promptly
Charging	Solid Red	Charging
Fully charged	Red light off	Fully charged

Displays connection status, battery level, and mute status.

Group Indicator:

Solid A: Headset assigned to Group A

Solid B: Headset assigned to Group B

Off: Headset not assigned to any group

Microphone Boom Indicator:

Solid red: Microphone muted

Solid green: Noise reduction enabled

Blinking blue: Not connected

Solid blue: Connected (noise reduction off)

Modular Wearing Configuration

Dual-Ear Headset → Single-Ear Headset

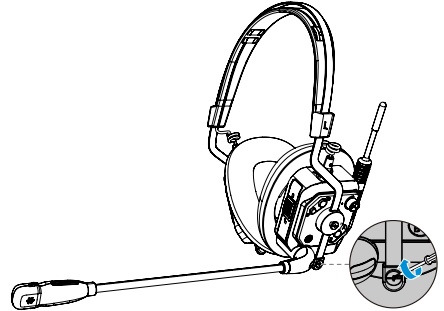

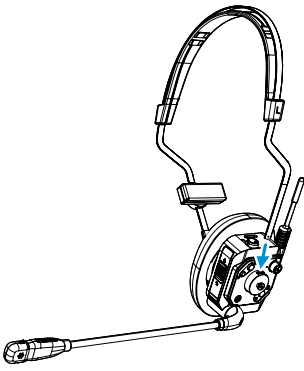

Dual-Ear Headset → Helmet-Style Dual-Ear Headset

- 1 Remove the standard headband.

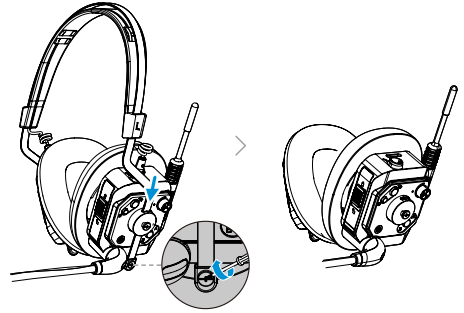

- 2 Attach the headset to the helmet mounting bracket.
- 3 Remove the over-ear earpads.
- 4 Secure the bracket to the helmet's side mounting slot using the clips.

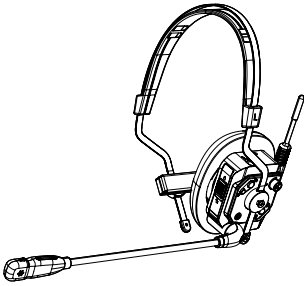

- 1 Install the T-shaped silicone pad on the non-earcup side to ensure a secure fit.
- 2 Adjust the headband length for comfort.
- 3 Application:
Suitable for roles such as directors or coordinators who need to monitor ambient sound while communicating.

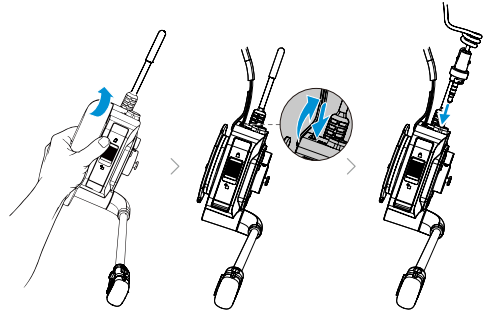

Dual-Ear Headset Configuration (Optional Accessory Required)

- 1 Remove the T-shaped pad from the non-earcup side of the headset.
- 2 Insert the dual-ear connection cable into the modular port until it clicks into place.
- 3 Route the cable behind the head and position both earcups over the ears.
- 4 Application:
Suitable for directors or camera operators requiring noise isolation in high-noise environments (e.g., concerts or racetracks).

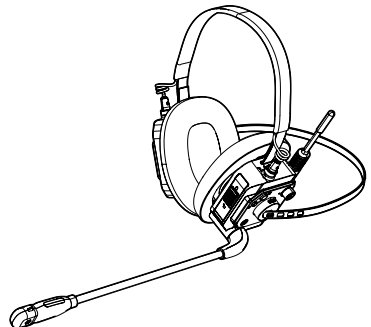
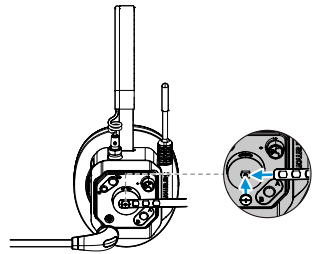

⑤ Application:

Suitable for environments requiring a safety helmet, such as construction sites, motorsport maintenance, and cycling shoots.

Using the Device

Power On / Power Off

Power On:

With the device powered off, press and hold the Power button for approximately 2 seconds until you hear "Power on" or "开机".

Power Off:

With the device powered on, press and hold the Power button for approximately 2 seconds until you hear "Power off" or "关机".

Volume Adjustment

Increase Volume: Rotate the volume knob clockwise.

When the maximum level is reached, a "Maximum volume" prompt is heard.

Decrease Volume:

Rotate the volume knob counterclockwise.

Microphone Mute

The WiTalk9 X provides two ways to mute the microphone:

Boom Mute:

Flip the microphone boom up to mute. A "Mute on" or "静音开启", prompt is heard, and the indicator turns red.

Fold down the microphone boom to unmute. A "Mute off" or "静音关闭", prompt is heard.

Button Mute:

Short press the "Mute" button on the headset body to mute or unmute the microphone.

Noise Reduction

Noise Reduction Off (Original Sound):

Default setting. Suitable for quiet environments such as indoor use, studios, and interviews.

Features: Preserves vocal detail without clipping or muffling, suitable for soft or low-volume voices.

Voice prompt: "Noise reduction off" / "降噪关闭"

Noise Reduction On:

Suitable for noisy environments such as concerts, racetracks, and factories.

Features: Reduces background noise while maintaining speech clarity for commands.

Voice prompt: "Noise reduction on" / "降噪开启"

Note: In extremely high sound pressure level (SPL) environments (e.g., concerts or music festivals), disable noise reduction to maintain clear communication.

Group Channel Switching

Allows switching between assigned communication groups (e.g., Director Team and Camera Team).

Operation: Short-press the "A/B" button to switch groups.

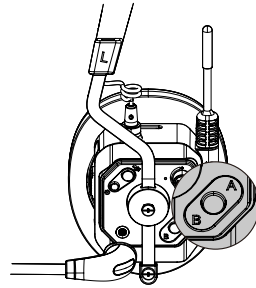

Voice prompt: After switching, the headset announces the current group (e.g., "Team A" / "A组", "Team B" / "B组"). Note: This function is available only when used with the WiTalk BASE and after group configuration in the app. If no group is configured, the button is inactive and the indicator remains off.

External 3.5 mm Earphone Connection

The WiTalk9 X supports audio monitoring via an external earphone, reducing head and neck strain and enabling discreet monitoring.

Required accessory: 2.5 mm to 3.5 mm adapter (included).

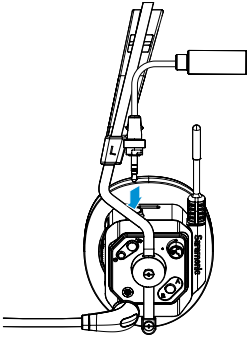

Usage: Audio is output through the external earphone. The master headset can be clipped to a belt or worn on a lanyard. Speak using the built-in microphone or a compatible wired earphone with an inline microphone. (The earphone must be compatible with the WiTalk9 X master headset.)

Application:

Suitable for long-duration shooting to reduce neck strain, or for situations requiring discreet monitoring.

Announce / PTT (Push-to-Talk)

Master Headset – Announce Mode

Operation: Press and hold the volume knob to speak; release the knob to mute the microphone.

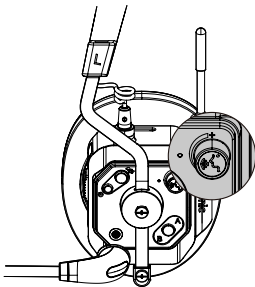

Function: Activates Announce Mode. The master headset broadcasts to all headsets. Remote headsets are temporarily muted (listen-only).

Application: Suitable for roles such as directors or coordinators delivering instructions without interruption.

Exit: Press the Mute button or fold down the microphone

boom to return to normal full-duplex communication.

Remote Headset - PTT (Push-to-Talk)

Operation: Press and hold the volume knob to speak; release to mute.

Function: The headset's microphone is muted by default. Press and hold the volume knob to speak; release to mute.

Application: Suitable for roles such as camera operators or lighting staff who speak intermittently, reducing background noise from continuously interfering with the team channel.

Exit: Press the Mute button or lower the microphone boom to return to normal full-duplex communication.

Pairing & Connectivity

Automatic Pairing (Factory Paired) Standard packages are pre-paired at the factory.

- ① Power on the Master headset first.
- ② Power on the Remote headsets one by one.
- ③ Wait 5-10 seconds. The indicator changes from blinking blue to solid blue, indicating a successful connection.

Manual Pairing (for adding new headsets or re-pairing)

- ① Ensure both the Master and Remote headsets are powered off.
- ② On the Master headset, press and hold the Power and Mute buttons simultaneously for approximately 5 seconds. The indicator alternates red and blue, then turns off, indicating the pairing list has been cleared.
- ③ Press and hold the Power button on the Master headset for approximately 5 seconds until the indicator blinks blue rapidly and a pairing tone is heard.
- ④ Press and hold the Power button on each Remote headset for approximately 5 seconds until the indicator blinks blue rapidly and a pairing tone is heard.
- ⑤ When the Remote headset indicator changes from fast blinking blue to slow blinking blue, pairing is complete.
- ⑥ If fewer than 8 remote headsets are paired, press the Power button on the Master headset to exit pairing mode. The system will return to normal operation.
- ⑦ If 8 remote headsets are already paired, the Master headset cannot enter pairing mode. The indicator will blink red.

Connecting to the WiTalk BASE Station

The WiTalk9 X can be used as a remote unit within the WiTalk BASE system to support larger communication setups. For details, refer to the WiTalk BASE documentation.

APP Management

Download and install the Saramonic App or Saramonic System App, then connect to the Master headset or WiTalk BASE station to access the following features:

1. Battery Monitoring: View real-time battery status of connected headsets.
2. Group Management: (with WiTalk BASE) Assign headsets to communication groups (e.g., Lighting Team, Camera Team).
3. Mode Switching: Switch noise reduction on or off.
4. Firmware Upgrade: Update headset firmware via OTA to access the latest features.

Note: When connected to the WiTalk BASE Station, remote monitoring and configuration require the Saramonic System App (group management software).

Specifications

Wireless Technology	DECT (1.9 GHz) (varies by regional version)
Transmission Range	Up to 400 m line-of-sight (LOS)
Frequency Response	150 Hz – 7 kHz (Wideband voice)
Signal-to-Noise Ratio	> 70 dB
Total Harmonic Distortion	< 1%
Latency	< 75 ms
Microphone Type	Dual-microphone array with AI adaptive noise reduction
Battery Capacity	1000 mAh / 3.7 V (removable lithium battery)
Battery Life	Master headset: > 9 hours (with 4 remote headsets) Remote headset: > 13 hours
Charging Port	USB-C(5 V/1 A)
Operating Temperature	-10°C ~50°C
Dimensions (L × W × H)	Theoretical value: 191.33×140.14×75.5 mm
Weight	Approx. 172 g (with battery)
Dual-ear Headset	
Weight	Approx. 264 g (with battery)
Dimensions (L × W × H)	Theoretical value: 191.33×171.34×75.5 mm
Helmet-style Dual-ear Headset	
Weight	Approx. 235 g (with battery)
Dimensions (L × W × H)	Theoretical value: 175.55×116.49×75.5 mm

Troubleshooting

Unable to power on

- 1) Ensure the battery is installed correctly.
- (2) Ensure the battery has sufficient charge. Recharge and try again.

No sound from the headset

- 1) Ensure the volume is not set too low.
- (2) Ensure other headsets are not muted (microphone boom folded up).
- (3) Ensure the indicator is solid blue (connected).

Short communication range or frequent disconnection

Ensure there are no large metal objects or concrete walls causing interference. Adjust the headset position or reduce the distance between units.

Unclear audio in noisy environments

Ensure Noise Reduction is enabled to suppress background noise.

Clipped speech or missing words in a quiet live-streaming studio

Ensure noise Reduction is disabled in quiet environments to preserve more vocal details.

Unable to pair headsets

- (1) Ensure the Master and all Remote headsets are in pairing mode (indicator blinking blue rapidly).
- (2) When connecting to the headsets of WiTalk9 system, ensure all headsets are updated to the latest firmware for compatibility.
- (3) WiTalk system headsets do not support hybrid wireless networking.

After-Sales Service & Warranty

Warranty Period: Headsets: 12 months

Accessories and batteries: 6 months (Subject to local laws and regulations)

Warranty Exclusions: Damage caused by misuse, water ingress, unauthorized disassembly or repair, or force majeure is not covered.

The modular design of the WiTalk9 X allows optional accessories to be purchased and replaced as needed.



For better recording experience, the application **Saramonic** is recommended.

为获得更好的录制体验，推荐使用枫笛 Saramonic 自主研发应用软件 **Saramonic**。



Scan the QR Code to Access the Complete User Manual 扫码获取《用户手册》



Scan the QR Code to Access the Tutorial Videos 扫码观看操作教程

Shenzhen Jiayz Photo Industrial., Ltd
深圳市长丰影像器材有限公司

A16 Building, Intelligent Terminal Industrial Park of Silicon Valley
Power, Guanlan, Longhua District, Shenzhen, China
深圳市龙华区观澜街道大富工业区硅谷动力智能终端产业园A16栋

☎ 400-613-1096 🌐 www.saramonic.com ✉ support@saramonic.com