

Saramonic

Intercom System Master Console
通话系统主站控制台

WiTalk BASE

User Manual
用户手册

1 Product Profile

1.1 System Overview

WiTalk BASE is a full-duplex wireless intercom system designed for professional collaboration scenarios such as film and television production, live events, and on-site coordination. The system supports simultaneous talk and listen for multiple users without push-to-talk activation, meeting the real-time collaborative communication needs of teams in complex on-site environments.

1.2 System Capabilities

- A single WiTalk BASE station can connect up to 16 terminal devices, and larger-scale deployments can be achieved through multi-base station cascading.
- The system supports up to 8 independent talk groups, meeting the parallel communication needs of multiple groups such as the Director Group, Camera Group, Lighting Group, and Audio Group.
- The communication range between the base station and headsets can reach up to 500 meters under unobstructed, line-of-sight conditions. Actual communication range may vary depending on on-site obstructions, installation height, electromagnetic environment, and usage conditions.
- WiTalk BASE stations support wired cascading via LAN, allowing the system to scale up to 4 base stations with a maximum total capacity of 64 terminal devices.
- In multi-base station coverage scenarios, connected terminals can automatically roam and switch between different base station coverage areas.

1.3 Audio Performance

- Supports wideband voice communication with a 16 kHz audio sampling rate, frequency response range of 100 Hz–7 kHz, signal-to-noise ratio >55 dB, and distortion rate <1%.
- Employs ENC multi-microphone array and noise reduction algorithms to suppress background interference in complex noise environments, thereby improving speech intelligibility and communication efficiency.
- Adopts a 1.9 GHz DECT wireless transmission solution with strong anti-interference capability. Specific available frequency bands, certification requirements, and sales versions are subject to target market regulations and actual shipping versions.

1.4 Interfaces and Expansion

- The base station is equipped with LAN, 4-Wire, UAC, 3.5 mm, and other interfaces for audio connectivity and signal interaction with mixing consoles, two-way radios, computers, and other devices.
- Supports DHCP and static IP network configuration for convenient Web management, system configuration, and maintenance across different LAN environments.
- Supports audio interconnection with certain third-party wired intercom or audio systems via the 4W interface. Compatibility depends on the remote device's interface definition, pin-out, and level settings.

1.5 Power Supply and Management

- Supports V-Mount / G-Mount battery and DC adapter power supply to accommodate different on-site deployment requirements.
- Supports configuration and management via the base station's local interface, Web interface, and App.
- The base station supports local and online firmware upgrades; headset firmware update methods depend on the specific model and current system configuration. Please refer to the corresponding chapter for detailed instructions.

2 Packing List

2.1 Kit Description

WiTalk BASE is available in multiple kit configurations, and the package contents may vary depending on the model. Please refer to the actual purchased version and the packing list card included in the package.

2.2 Package Contents

- WiTalk BASE Station
- Single-Ear Headset (configuration varies by kit version)
- Dual-Ear Headset (configuration varies by kit version)
- Helmet Headset (configuration varies by kit version)
- Headset External Battery
- 10-Slot Charging Case
- Over-Ear Cushions
- On-Ear Cushions
- Single-Ear Head Pad
- Microphone Windscreen
- USB Type-A to Type-C Cable
- Base Station Antenna
- User Manual
- Warranty Card

3 Base Station Structure and Interface Description

3.1 Base Station Appearance and Component Names

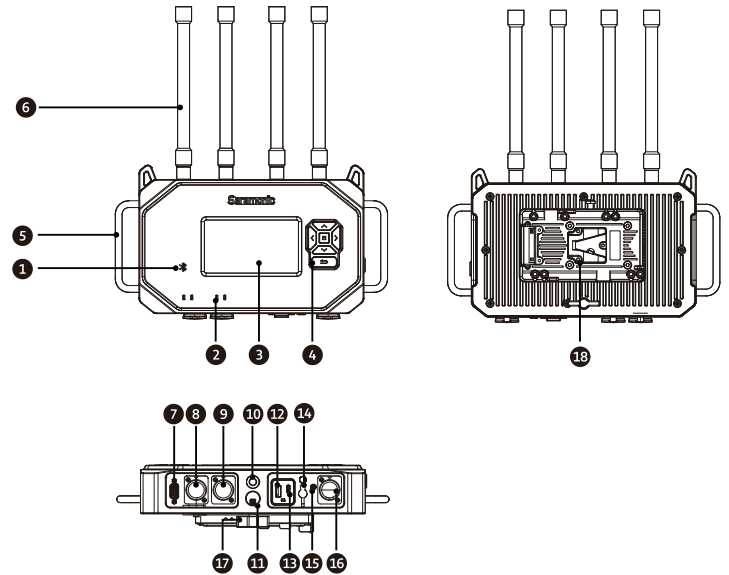

The WiTalk BASE station consists of the following main components:

- ① Bluetooth Indicator Light
- ② IP Status Indicator Light
- ③ Display
- ④ Function Button Area
- ⑤ Handle
- ⑥ Antenna Connector and Antenna
- ⑦ Reserved Expansion Port (not for user operation in the current version)
- ⑧ RJ45 LAN 1 Port
- ⑨ RJ45 LAN 2 Port
- ⑩ 3/8" Mounting Screw Hole
- ⑪ 5/8" Mounting Interface
- ⑫ USB-A Port
- ⑬ USB-C Port
- ⑭ DC Power Port
- ⑮ 3.5 mm Audio Port
- ⑯ RJ45 4W Audio Port
- ⑰ Locking Knob
- ⑱ V-Mount / G-Mount Battery Plate Mounting Position

3.2 RJ45 LAN 1 / RJ45 LAN 2 Interface Description

Pin-out

The RJ45 LAN 1 / RJ45 LAN 2 ports are used for LAN cascading and system synchronization between WiTalk BASE stations. These ports are primarily used for audio, group, and system management data transmission in multi-base station expansion scenarios.

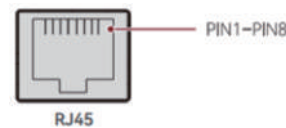

- Standard Pin-out
- PIN 1 Transceive Data+
 - PIN 2 Transceive Data-
 - PIN 3 Receive Data+
 - PIN 4 CLK 100Hz+
 - PIN 5 CLK 100Hz-
 - PIN 6 Receive Data-
 - PIN 7 CLK GND
 - PIN 8 CLK GND

Usage Instructions

These ports are only intended for system interconnection between WiTalk BASE stations.

It is not recommended to use these ports as general network switch ports, PoE ports, or other general-purpose RJ45 ports. When cascading base stations, it is recommended to use CAT5e or CAT6 shielded cables to reduce the impact of external electromagnetic interference on system stability.

It is recommended that the length of a single cable segment does not exceed 100 meters.

Precautions

LAN cascading is a digital signal interconnection and only supports communication between WiTalk BASE stations.

Do not connect to routers or other third-party devices.

For multi-base station systems, please refer to Section 4.5 for network role configuration.

3.3 RJ45 4W Audio Interface Description

The RJ45 4W audio port is used for 4W audio interconnection between WiTalk BASE and similar systems or certain third-party wired intercom/ audio systems. The original documentation clearly states that this interface supports both standard and crossover pin configurations and is used for internal WiTalk system connections or interfacing with third-party systems.

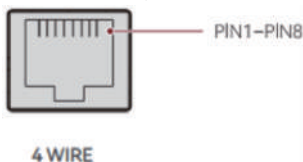

Pin-out Modes

The RJ45 4W audio port supports the following two modes:

1. Standard Mode

Suitable for internal WiTalk system connections or external devices with pin definitions consistent with WiTalk.

Standard Pin-out	
PIN 1	GND
PIN 2	GND
PIN 3	Audio In+
PIN 4	Audio Out+
PIN 5	Audio Out-
PIN 6	Audio In-
PIN 7	GND
PIN 8	GND

2. Crossover Mode

Suitable for connecting certain third-party devices with reversed input/ output pin definitions.

Crossover Pin Configuration	
PIN 1	GND
PIN 2	GND
PIN 3	Audio Out+
PIN 4	Audio In+
PIN 5	Audio In-
PIN 6	Audio Out-
PIN 7	GND
PIN 8	GND

Usage Recommendations

When connecting to a third-party system, if any of the following issues occur:

- No audio
- Abnormal input/output direction
- Abnormal level
- Mismatched transmit/receive audio
- Please first verify the remote device's interface definition, then switch between Standard Mode and Crossover Mode in the WiTalk BASE menu and retest.

Precautions

1. The 4W port is an analog audio interface that only transmits audio signals and does not transmit system control or network synchronization information.
2. Compatibility depends on the remote device's interface definition, pin configuration, and level settings.
3. If the third-party device does not use a standard RJ45 wiring scheme, a compatible adapter solution is required.
4. If there is a noticeable volume difference, you can adjust the level gain in the 4W input/output settings in the base station menu.

3.4 Product Parameters

Base Station Basic Parameters

Base Station Basic Parameters	
Product Name	WiTalk BASE Station
Transmission Distance	500 m
Wireless Transmit Power	≤21 dBm
Channel Width	1.728 MHz
Modulation	GFSK
Frequency Response	100 Hz to 7 kHz (± 3 dB) @1 kHz
Receiving Sensitivity	≤-90 dBm
Signal-to-Noise Ratio	>55dB
Distortion	<1%
Antenna Gain	4 dBi (Omnidirectional)

Power Supply Parameters

DC Power Supply Range	7-30V, <1 A@12 V
V/G Mount Battery Power Supply Range	11-30V, <1 A@12 V
Total Power Consumption	<1 A@12 V

Mechanical Parameters

Dimensions	325×182×79mm (without antenna) 325×430×79mm (with antenna)
Weight	1,960 g (without antenna) 2,490 g (with antenna)

Environmental Parameters

Operating Temperature	-10° C to 45° C
Storage Temperature	-20° C to 60° C

4 Product Usage

4.1 Antenna Installation

To achieve more stable wireless coverage, WiTalk BASE supports two common antenna installation methods. Two installation approaches are provided: One is a parallel arrangement, and the other is a cross-polarized arrangement.

Method 1: Parallel Antenna Arrangement

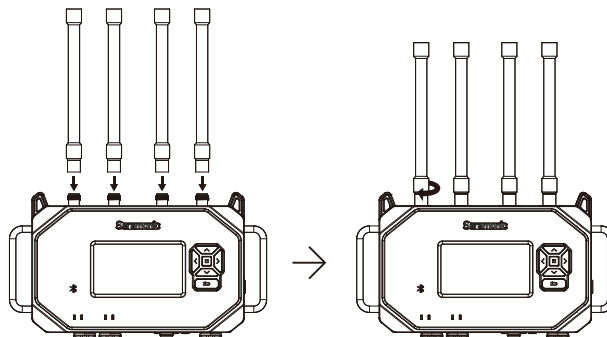

Applicable Scenarios:

Suitable for fixed installations, open-area deployments, or sites with minimal obstructions.

Features:

Helps maintain consistent antenna orientation; suitable for standard fixed deployment scenarios.

Method 2: Cross-Polarized Antenna Arrangement

Install the adapter first, then the antenna as shown in the illustration, so that the antennas form a cross-polarized arrangement.

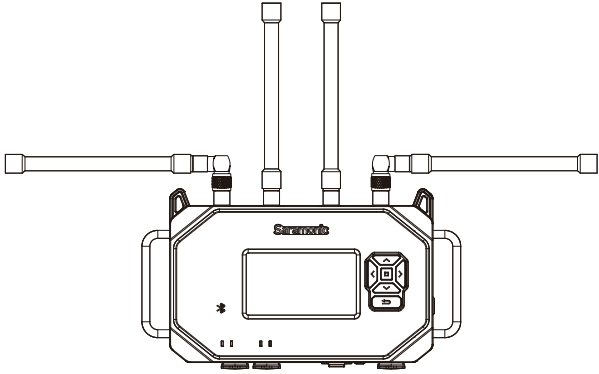

Applicable Scenarios:

Suitable for indoor environments, multipath reflection environments, sites with complex obstructions, or locations with high personnel movement.

Features:

Helps improve link stability and obstruction resistance.

Installation Recommendations

After antenna installation, make sure all antennas are tightened and securely fastened.

During use, avoid having antennas completely blocked by metal structures, walls, or large equipment.

If the site environment is complex, try the cross-polarized arrangement first to improve link stability.

4.2 Power Supply Connection

WiTalk BASE supports power supply via battery or DC adapter.

Method 1: Battery Power Supply

Depending on the kit purchased and battery type, install the corresponding V-mount battery plate or G-mount battery plate onto the base station.

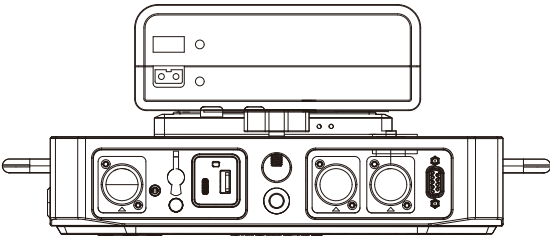

Operating Recommendations:

1. Before installing or replacing the battery plate, make sure the base station is powered off.
2. After installation, confirm that the plate is securely fastened.
3. After connecting the battery, press the power button to turn on the unit.

Method 2: DC Adapter Power Supply

Connect the power adapter to the DC power port on the base station. After connecting the power supply, press the power button to turn on the unit.

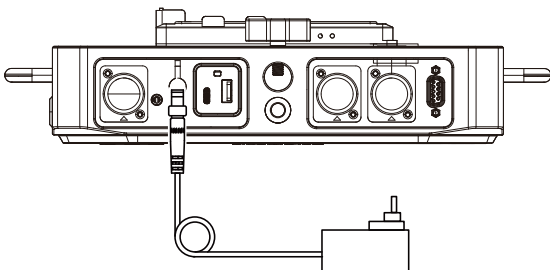

Operating Recommendations:

1. Please use a power adapter that meets the specifications of this unit.
2. Refer to Section 3.4 for the power supply voltage and current range.

3. For long-term fixed deployments, it is recommended to verify the stability of the external power supply first.

4.3 Tripod Installation

WiTalk BASE can be mounted on a tripod or other stable support system.

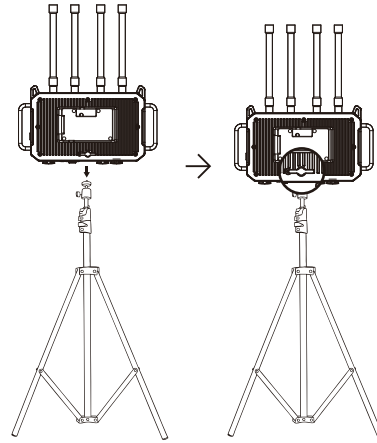

Installation Steps

- ① Mount the base station onto a tripod or support system.
- ② Tighten the locking knob to ensure the base station is securely mounted.
- ③ If necessary, add sandbags or other counterweights to improve overall stability.

Setup Recommendations

- ① It is recommended to elevate the base station to approximately 1.7 meters or a more suitable height to improve wireless coverage.
- ② Avoid large metal obstructions, thick walls, or strong electromagnetic interference sources around the base station.
- ③ For complex site deployments, prioritize a stable location with an open line of sight and easy access for operating the base station.

4.4 Product Connection

4.4.1 Kit Usage

Users who purchase a complete kit do not need additional pairing, as the base station and headsets are already paired at the factory.

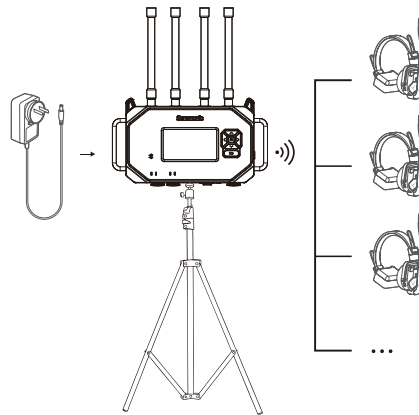

Usage Steps:

- ① Connect the base station to a power source and turn it on;
- ② Turn on the headset;
- ③ The headset will automatically search for and connect to the base station;
- ④ Once connected, communication can begin.

Recommendations

For a more stable automatic connection experience, it is recommended to turn on the base station first, then turn on the headsets one by one.

4.4.2 Pairing Legacy Headsets with the Base Station

When pairing a legacy WiTalk series headset with the WiTalk BASE station, first confirm the headset model and the corresponding upgrade method.

Compatibility Notes

WiTalk5: Not compatible with WiTalk BASE.
 WiTalk9: Compatible with WiTalk BASE; supports wireless pairing and BLE upgrade only.
 WiTalk9 X: Compatible with WiTalk BASE; supports USB wired upgrade.

WiTalk9 X Wired Upgrade

When the headset supports upgrading via USB, follow the steps below:
 Steps:
 Connect the headset to the USB-A port on the WiTalk BASE station using a USB cable;
 When the base station detects that the headset firmware version differs from the current system version, an upgrade prompt will automatically appear on the screen;
 Select "Yes" and the system will begin the firmware upgrade for the connected headset;
 During the upgrade, the headset indicator light will flash;
 After the upgrade is complete, the headset will automatically power off or restart;
 After the base station exits the upgrade screen, turn the upgraded headset back on for normal use.

Note:
 Do not disconnect the power or unplug the cable during the upgrade process;
 To connect to the WiTalk BASE system, please complete the headset upgrade first.

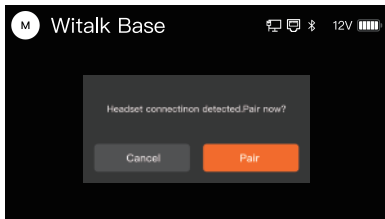

WiTalk9 Wireless Upgrade and Wireless Pairing

WiTalk9 does not support wired connection to the WiTalk BASE station. Wireless pairing must be completed first, followed by BLE upgrade.

Steps:

- ① Enter Pairing Mode
 In the base station menu, select:
 [Menu] → [Headset Management] → [Headset Pairing]
 After the base station enters pairing mode, the screen displays a "Pairing" prompt.
- ② Power On the Headset and Enter Pairing
 Press and hold the WiTalk9 headset power button for 8 seconds. The headset enters pairing mode and begins searching for the base station signal.
 Once the signal is successfully detected, the base station will automatically establish a connection with the headset.
- ③ Firmware Upgrade
 When the base station detects that the headset firmware version does not match the current system version, the system will automatically initiate the BLE upgrade process.

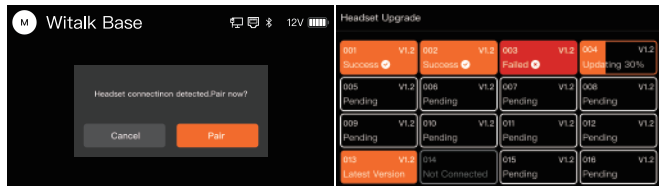

After selecting "Yes", the system will perform a wireless upgrade on all connected headsets that require updating.

- ④ Upgrade Complete
 After the upgrade is complete, the headset will automatically restart.
- ⑤ Pairing Complete / Exit
 During the pairing process, the base station screen displays in real time:
 Number of currently connected headsets
 Number of headsets currently being paired
 When the total number of registered headsets in the base station reaches 16, the system automatically ends pairing mode and displays a "Pairing Complete" prompt.

Users can also manually select "End Pairing" to exit. If no headset connection is detected within the set time, the system will automatically exit and display the prompt "Pairing ended, no headsets paired".

Note:

Wireless pairing does not support manual number selection. The system automatically assigns channels and numbers based on the headset connection order. When the base station enters pairing mode, a "Pairing" prompt is displayed on the screen.

4.5 Product Cascading

4.5.1 Dual Base Station LAN Cascading

When two WiTalk BASE stations need to achieve greater coverage or higher system capacity, they can be cascaded via the RJ45 LAN interface. This method is only applicable for interconnection between WiTalk BASE stations, used for synchronized transmission of system signals and audio.

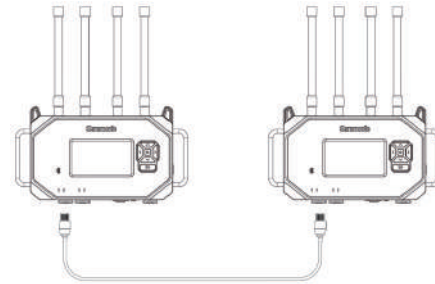

Use a CAT5e / CAT6 shielded Ethernet cable to connect the RJ45 ports (LAN1) of the two WiTalk BASE stations. The total cable length should not exceed 100 meters.

Setup Steps

Configure the following settings on each of the two base stations:
 Base Station ①: Go to [Network Settings] → [Master/Slave Mode], and select Master.
 Base Station ②: Go to [Network Settings] → [Master/Slave Mode], and select Slave.

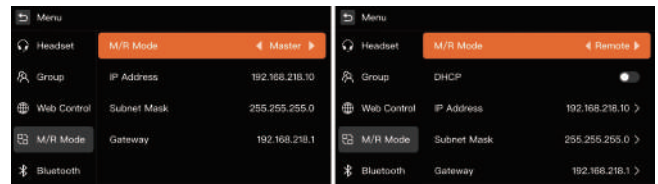

System Description

After the two base stations are cascaded via the RJ45 LAN port, audio, grouping, and call management information can be synchronized. Once cascading is complete, headset users on the slave station can communicate with groups on the master station for cross-base intercom.

Precautions

LAN cascading is a digital signal interconnection and only supports communication between WiTalk BASE stations.
 Do not connect to routers or other third-party devices.
 Shielded Ethernet cables are recommended to avoid external electromagnetic interference.
 A single cable run should not exceed 100 meters.

① Connection Method

Use a CAT5e / CAT6 shielded Ethernet cable to connect the RJ45 ports (LAN1) of the two WiTalk BASE stations.
 The total cable length should not exceed 100 meters.

Fiber Optic Access Instructions

The LAN1 / LAN2 interfaces of the WiTalk BASE do not support direct fiber optic cable connection.
 If the on-site cabling distance is long, or transmission via fiber optic links is required, the following solution is recommended:
 Add a media converter between the WiTalk BASE LAN interface and the fiber optic link.
 First, connect the base station to the electrical port of the media converter using a standard Ethernet cable.
 Then connect the two media converters via fiber optic cable to extend the link.

Media converters and associated switching/transmission equipment must be configured by the user according to the on-site network environment.

Recommendation:

Industrial-grade or broadcast-grade media conversion equipment is preferred. Complete link connectivity and stability testing before putting the system into production use.

4.5.2 Multi-Base Station LAN Cascading

When a larger-scale team communication system is required, up to 4 WiTalk BASE stations can be interconnected through cascading.

Connection Method

1. Use CAT5e / CAT6 shielded Ethernet cables to connect the LAN1 interface of each base station to an external cascading distributor.
2. Each base station is independently powered.
3. Set the master/slave relationship in the base station menu:

- ① Set the first unit as Master.
- ② Set the remaining base stations as Slave.

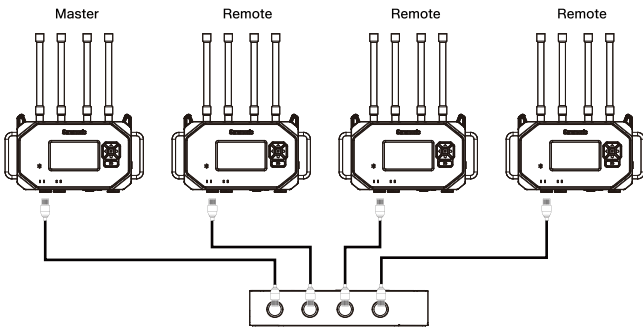

System Description

After multi-base station cascading, network signal and audio intercommunication between base stations is enabled to extend system coverage and access capacity.

Precautions

The system supports cascading of up to 4 WiTalk BASE stations. Cascading is only supported between WiTalk BASE stations of the same model. Cable length should not exceed 100 meters. Cascading via RJ45 only enables network and audio intercommunication between base stations.

Fiber Optic Access Instructions

When the deployment distance between multiple base stations exceeds the applicable range of standard Ethernet cables, the link can be extended using an Ethernet cable + media converter + fiber optic link + media converter + Ethernet cable configuration.

Note:

Fiber optic cables cannot be directly plugged into the LAN1 / LAN2 interfaces. The fiber optic extension solution must ensure compatibility and stable power supply of network equipment at both ends. It is recommended to complete full cascading link testing before live performances or formal project deployment.

4.5.3 4W Audio Interconnection with Third-Party Systems

The WiTalk BASE supports audio interconnection with third-party wired intercom or audio systems via the 4Wire (RJ45) interface. This feature enables two-way audio communication between the WiTalk system and third-party base stations, suitable for large events, broadcast studios, or cross-system collaboration scenarios.

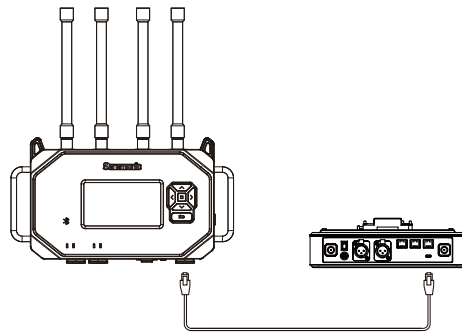

Connection Method

Use a standard CAT5e / CAT6 Ethernet cable to connect the WiTalk BASE to the 4Wire interface or differential audio interface of the third-party base station. The total cable length should not exceed 100 meters.

Precautions

- The 4W interface is an analog audio signal interface that transmits audio signals only.
- It does not transmit system control, group management, or network synchronization information.
- Please confirm the 4W interface type and pin definitions of the third-party base station.
- If there is a noticeable volume difference, adjust the level gain in the WiTalk BASE under [Audio Settings] → [4W Input/Output].

Interface Adaptation Instructions

The WiTalk BASE provides the pin-out definition for the 4Wire interface. Users with cable modification capabilities can fabricate or modify adapter cables according to the interface type and pin definitions of the third-party master device to complete the connection.

For example, users can modify the RJ45 end to adapt to the target device's:

- XLR interface
- Phoenix interface
- Other corresponding analog audio interfaces

Recommendation:

- Before modifying cables, please confirm the input/output definitions, balanced configuration, and level requirements of the third-party device.
- If you have no cable modification experience, it is recommended that a technician with audio system wiring experience perform the operation.
- Before connecting, perform a standalone audio test to confirm that the send/receive direction and levels are normal before putting the system into production use.

Pin-out Modes

If the other system uses a "straight-through" port, select [Standard Mode] on the WiTalk BASE.

If the other system uses a "crossover" port, select [Crossover Mode] on the WiTalk BASE.

4.6 Quick Group Settings

The WiTalk BASE supports up to 8 talk groups and introduces a new headset Role concept. Through the role-based grouping mechanism, users can achieve "one-click grouping and quick configuration" on the base station, local Web interface, or mobile App, reducing the need to configure headset parameters one by one before powering on.

The following uses base station operation as an example to explain how to quickly complete grouping and role assignment.

- ① Enter Group Settings

Press and hold the base station menu button to enter the main menu. Select [Group Settings] from the menu to enter the group settings interface.

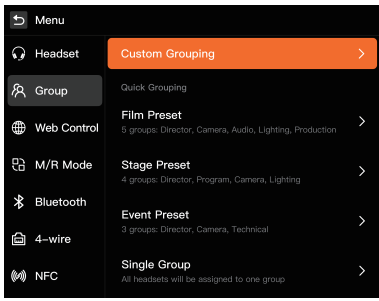

② Select a Preset Plan

After entering the [Group Settings] page, the system provides the following preset plans:

Custom Grouping: Users can freely configure roles and the number of groups according to project requirements.

Film & TV Preset: Suitable for film and TV production, commercials, short dramas, and other collaborative scenarios (director, camera, sound, lighting, etc.).

Stage Preset: Suitable for stage performances, conferences, large events, and other fixed-position scenarios.

Event Preset: Suitable for mobile scenarios such as conferences, exhibitions, press conferences, and event execution teams.

One-group mode: Assign all communication devices (headsets, 4W, UAC, 3.5mm, etc.) to the same group to enable full intercommunication. Click [Custom Grouping] to enter the role assignment page, where you can manually adjust the number of headsets for each role.

③ Role Group Description

In the WiTalk system, Role Groups are used to define the communication attributes and permissions for each position. Each role not only represents a communication position (e.g., Director Group, Camera Group, Lighting Group, etc.), but also determines the group assignment, A/B grouping relationship, and communication mode of the headsets in that group within the system.

A role group can be understood as:

Position identity + Communication permissions + Grouping relationship
Through role group configuration, users can quickly establish communication structures for different scenarios to achieve a "position-as-group" logic, thereby improving deployment efficiency and team collaboration clarity.

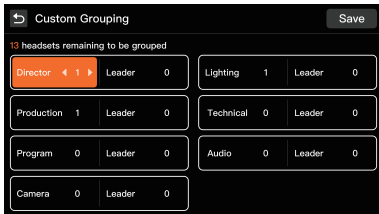

④ Management Group Description

Group 1 is the default management group.

Only roles designated as team leaders can join Group 1.

For roles in the management group, Group 1 is set as the default to facilitate priority communication among management members

⑤ A/B Grouping Description

After A/B virtual grouping is configured, each headset can switch between Group A and Group B using the grouping button.

A: The default group of the headset

B: The other virtual group the headset can switch to

After completing the A/B grouping configuration, the headset can hear audio from both Group A and Group B simultaneously;

However, speech will only be sent to the currently active group.

For example:

When the headset is currently in Group A, speech is only sent to Group A;

To speak in Group B, you need to press the grouping button on the headset to switch to Group B first.

⑥ Role Grouping Description (Taking Custom Settings as an Example)

WiTalk BASE includes multiple built-in commonly used role templates, including:

Director Group, Camera Group, Production Group, Lighting Group, Audio Group, Technical Group, Grip Group, etc.

Each role can be assigned to different grouping channels based on actual scenarios to enable multi-group parallel communication, inter-group isolation, and cross-group switching communication modes.

Role Matrix Description

The table below shows a role grouping example:

Rows represent role groups

Columns represent communication groups

A indicates the default group

B indicates the other group that can be switched to

Blank indicates the role is not assigned to that group

Role Name	Group 1	Group 2	Group 3	Group 4	Group 5	Group 6	Group 7	Group 8
Directing Leader	A	B						
Directing Member		B						
Cam Leader	A		B					
Cam Member			B					
Production Leader	A			B				
Production Member				B				
Lighting Leader	A				B			
Lighting Member					B			
Audio Leader	A					B		
Audio Member						B		
Tec Leader	A						B	
Tech Member							B	
Mobile Leader	A							B
Mobile Member								B

4.7 Upgrade Instructions

Note:

Before upgrading, please confirm the device model and corresponding upgrade method, and prepare the required firmware package.

WiTalk BASE station supports **web-based upgrade, OTA online upgrade, and USB flash drive upgrade.**

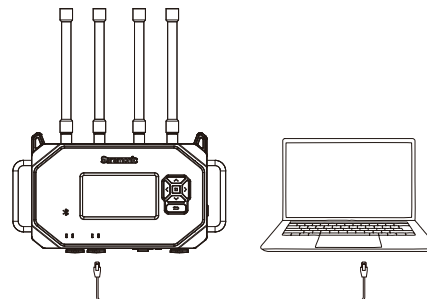

The mobile App does not support upgrading the WiTalk BASE station.

The upgrade methods for different headset models are as follows:

WiTalk9: Supports wireless upgrade only

WiTalk9 X: Supports both wired upgrade and wireless upgrade

4.7.1 WiTalk BASE Station Upgrade

Method 1: Web-based Upgrade

Before performing a Web-based upgrade, please download the corresponding firmware package first.

Steps

Use a standard RJ45 Ethernet cable to connect the base station's LAN port to the computer's network port;

Configure the computer's network settings so that its IPv4 address is on the same subnet as the base station.

For example: If the base station IP address is 192.168.1.xxx, set the computer to an address in the same subnet and ensure network connectivity.

Open a web browser on the computer and enter the base station's IP address in the address bar

(e.g., 192.168.1.1) to access the base station's Web login page;



Enter the account credentials to log in:

Username: admin

Password: 123456

If the account or password has been changed, enter the custom credentials to log in;

After logging in, select the following from the left menu:

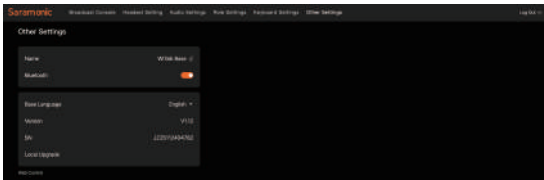

[Other Settings] → [Local Upgrade];

Drag the firmware package into the upgrade page window, or click the file selection area on the page to select the corresponding firmware package;

After the firmware upload is complete, click [Start Upgrade];

The system automatically performs the firmware update, and the base station automatically restarts after the upgrade is complete.

Note

The firmware package must be downloaded in advance for web-based upgrade;

Do not disconnect the power or network connection during the upgrade process;

After the upgrade is complete, you can check the current firmware version on the [About] page.

Method 2: OTA Online Upgrade (LAN2 Port Network)



OTA upgrades are automatically detected and downloaded when the base station is connected to the internet, eliminating the need to prepare a firmware package in advance.

Steps

1. Use a standard RJ45 Ethernet cable to connect the base station's LAN2 port to a router or switch with internet access;

2. Long press the base station menu button to enter the base station menu;

Select the following in order:

[Other Settings] → [WEB Control];

Set the automatic IP (DHCP) to enabled;

Once enabled, the base station can automatically obtain an IP address from the router and complete the network configuration;

Confirm that the base station is successfully connected to the network (network indicator light stays on or status displays "Connected");

Return to the main menu and select the following in order:

[Information] → [Firmware Upgrade];

The system automatically detects the latest version and prompts the user whether to upgrade;

During the upgrade process, the base station automatically downloads, installs, and restarts;

After the upgrade is complete, the base station runs the latest version.

Note:

OTA upgrade does not require downloading the firmware package in advance;

Please keep the network and power supply stable during the upgrade process;

If the network environment is restricted or internet access is unavailable, please use web-based upgrade or USB flash drive upgrade.

2. Users can access the [Custom Grouping] interface through the base station, Web, or App to adjust the quantity and roles of the above roles.

You can freely add or remove group members, modify group assignments, or designate any role as a "Leader".

3. After the settings are complete, click the "Save" button. The system will automatically complete headset assignment based on the configuration and synchronize to all connected headsets.

4. After completing the headset and role assignment, users can conduct group communication according to their assigned groups. All settings will be saved automatically and retained upon next power-on.

Method 3: USB Flash Drive Upgrade

Before upgrading via USB flash drive, prepare the required firmware package and copy the firmware file to the USB flash drive root directory. The device supports USB flash drives in EXFAT and FAT32 formats.

A. System Firmware Upgrade

Steps:

Copy the system firmware file to the root directory of the USB flash drive;

Insert the USB flash drive into the TYPE-A USB port of the device;

When the system detects a firmware version mismatch, it will automatically enter the installation interface and display the installation progress;

After the upgrade is complete, the base station will restart automatically.

B. APP Firmware Upgrade

Steps:

Copy the APP firmware file to the root directory of the USB flash drive;

Insert the USB flash drive into the TYPE-A USB port of the device;

When the system detects an APP firmware version mismatch, it will automatically enter the installation interface and display the installation progress;

After the upgrade is complete, the base station will restart automatically.

Note:

The firmware package must be downloaded in advance for USB flash drive upgrade;

System firmware and APP firmware cannot be placed in the root directory of the USB flash drive for upgrade at the same time;

Only one firmware file can be placed at a time;

After completing a firmware upgrade, delete the current firmware file before copying another one for upgrade.

Press and hold the [Menu] key on the base station for approximately 3 seconds to enter the main menu interface.

5 Base Station Menu Operations

5.1 Base Station Home Screen Status Description

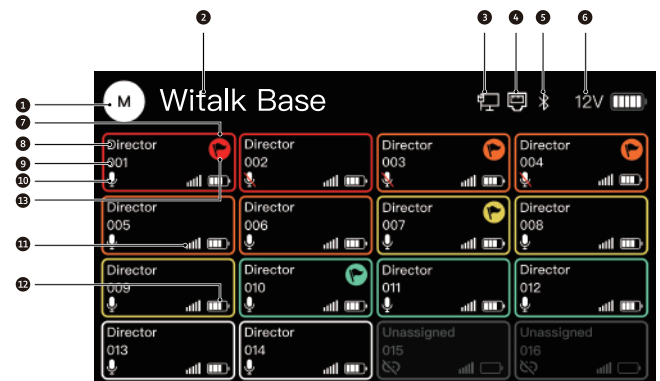

The WiTalk BASE home screen displays the system operating status, network connection status, and the connection and call status of each headset.

Users can quickly confirm the current base station role, network status, power supply status, as well as the role, number, online status, mute status, signal strength, and battery level of each headset on the home screen.

No.	Icon	Description
①		Indicates the master-slave mode of the base station., means the base station is the master device, means it is the slave device, and up to 8 devices can be added.
②	Witalk Base	Device name, which can be set in [My Devices in APP], and should be unique.
③		Indicates the connection mode of the base station, showing that it is connected to the PC.
④		Indicates the connection mode of the base station, showing that the device is in cascade mode. Device Data Circulation Cascaded base stations (max. 4 slave devices supported)
⑤		Indicates the connection mode of the base station, showing that it is connected to the APP.
⑥		Displays the mains power supply level of the base station currently in use. Displays the lithium battery power supply level of the base station currently in use. Indicates the base station is currently supplied with power via a V-type or G-type battery.
⑦		Indicates the color corresponding to the channel group, and different colors represent different channels. Red: Directing Orange:Cam Yellow:Audio Green:Lighting Cyan:Mobile Gray:Unassigned(X color: Blank color box for distinguishing different colors)
⑧	Director	Indicates the role of currently connected headset
⑨	001	Indicates the group number corresponding to currently connected headset
⑩		Indicates the call status of the headset. Indicates the headset is in a call. Indicates the headset is currently in mute mode. Indicates the current headset is currently disconnected or in an offline state.
⑪		Indicates the signal strength of the current connection of the base station.
⑫		Indicates the remaining battery power of the headset in the current channel.
⑬		Indicates the role of the currently connected headsets, with the leader indicator's color consistent with the color box.

Press and hold the [Menu] key on the base station for approximately 3 seconds to enter the main menu interface.

5.2 Headset Management

Headset management mainly includes the following functions:

Headset Pairing

Delete Headset

5.2.1 Headset Pairing

When a new headset needs to be added to the base station, pairing can be performed wirelessly.

Operation Path

In the main menu, select:

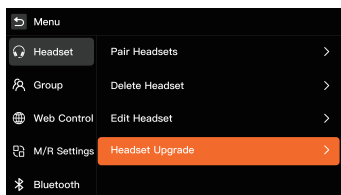

[Headset Management] → [Headset Pairing]

After the base station enters pairing mode, the screen displays "Pairing" and shows the number of paired headsets in real time.

Pairing Steps

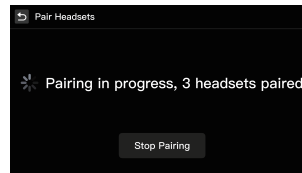

- ① Enter [Headset Pairing] on the base station;
- ② Press and hold the power button on the headset to be paired to enter pairing mode;
- ③ The headset automatically searches for and connects to the base station;
- ④ Each time a headset is successfully connected, the paired count on the base station increases in real time.

End of Pairing

The system will end the current pairing session under any of the following conditions:

- 16 headsets have been detected and registered

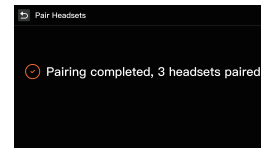

- The user manually clicks [Stop Pairing]

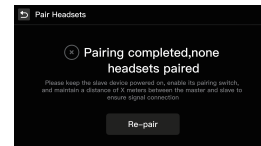

- Pairing times out with no new headset detected

Pairing Result Notification

When pairing is successful, the interface displays:

"Pairing complete, X headset(s) paired."

When no headset is detected before timeout, the interface displays:

"Pairing complete, no headset paired."

At this point, you can click [Re-pair] to start again.

5.2.2 New Headset Version Check and Upgrade Prompt

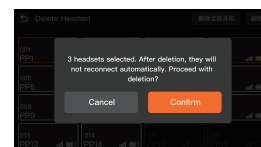

When the base station detects that the firmware version of a newly connected headset is inconsistent with the current system version, the system will automatically display an upgrade prompt window. After the user selects "Yes", the base station will initiate the corresponding upgrade process.

After the upgrade is complete, the headset will restart automatically; after restarting, it will automatically reconnect to the base station and function normally.

Note

Whether the upgrade is triggered depends on whether the headset's current firmware version is consistent with the system version; Please ensure the base station and headset are properly powered during the upgrade process; Do not force a shutdown or disconnect during the upgrade.

5.2.3 Pairing Precautions

Each pairing is only valid for the current base station and cannot be used across base stations;

In a multi-base station system, ensure that only one base station is in pairing mode to avoid interference;

If a version check is triggered after a new headset is connected, it is recommended to complete the upgrade before putting it into official use; It is recommended to complete headset pairing, upgrading, and call testing before the official project begins.

5.2.4 Delete Headset

When a headset is no longer in use or needs to be reassigned, the binding can be released through the [Delete Headset] function.

Steps

① In the main menu, select [Headset Management] → [Delete Headset] to enter the headset list page.

The screen displays all currently paired headset numbers (001–016), along with signal strength, battery level, and other status information.



② Tap to select the headset(s) to be deleted. Multiple headsets can be selected at once, or you can select [Delete All Headsets] with one tap; after clicking the [Delete] button in the upper right corner, the system will display a confirmation prompt:

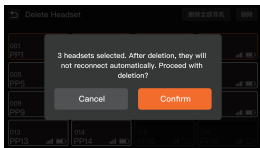

③ After selecting [OK], the base station performs the deletion, and the interface displays "Deleting"; after deletion is complete, it displays:

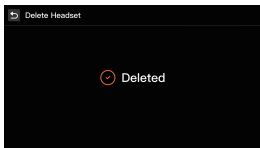

④ Deleted headsets must be re-paired before they can be used again.

Precautions:

- Deleting a headset only releases the binding and does not restore factory settings;
- A deleted headset will not automatically reconnect to the base station after powering on; the pairing process must be performed again;
- It is recommended to confirm each headset number and role assignment before the system runs stably to avoid accidental deletion.

5.3 Group Settings (See 4.6 Quick Group Settings for details)

5.4 WEB Control

Enter the [WEB Control] menu to configure the base station's network parameters and Web login information.

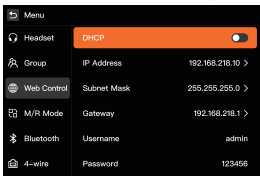

DHCP On: The base station automatically obtains an IP address, suitable for dynamic network environments such as routers and switches, and is also commonly used for OTA upgrade scenarios.

DHCP Off: Use a fixed IP address.

In fixed IP mode, users can manually set the following parameters:

IP Address

Subnet Mask

Gateway

Web Username

Web Password (Default: admin/123456)

Note:

When the base station is directly connected to a computer for Web management or local upgrade, it is recommended to use fixed IP mode and set the computer to the same network segment as the base station. For temporary use, you can directly enable DHCP to automatically obtain an IP address.

For long-term use, it is recommended to first obtain an available IP address via DHCP, confirm that the network connection is normal, then disable DHCP and fix that IP as the base station's long-term address for easier subsequent management.

5.5 Master/Slave Mode

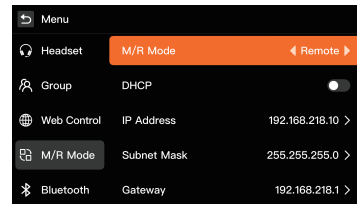

Enter the [Master/Slave Mode] menu to set the operating mode of the base station.

Master Device: Serves as the system's main control device, responsible for headset access, group configuration, and system management.

Slave Device: Connected to the master device for management in multi-base station cascading scenarios.

Note:

The master device can be used as a cascading main control device or independently as a standalone unit.

The slave device is primarily used in multi-base station cascading scenarios.

5.6 Bluetooth Settings

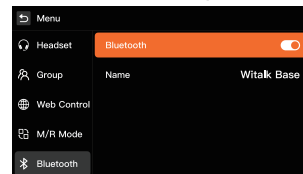

Enter the [Bluetooth] menu to view the base station's Bluetooth name and current connection status.

Bluetooth Status Description:

Indicator light solid on: Bluetooth is enabled

Indicator light off: Bluetooth is disabled

Note:

Each base station supports only 1 mobile device connected via Bluetooth at a time (such as a phone or tablet).

In multi-base station cascading scenarios, the BLE broadcast of slave devices will be automatically disabled.

5.7 4 Wire Settings

Enter the [4-Wire Settings] menu to adjust the input/output levels and wire configuration of the base station's 4W interface.

1. Select the [Input Gain] icon to adjust the gain level of audio received by the base station using the left/right direction keys, based on the input volume of the external signal source. Adjustment range: 0–100.

Recommendation: If the signal is weak, increase the gain appropriately to avoid signal overload and distortion.

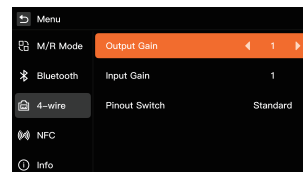

2. Select the [Output Gain] icon. Use the left/right direction keys to adjust the base station's audio output gain level according to the external device's receiving volume.

Adjustment range: 0–100. Recommendation: When connecting to an external mixer or intercom system, start with the default value of 60, then fine-tune based on actual monitoring conditions.

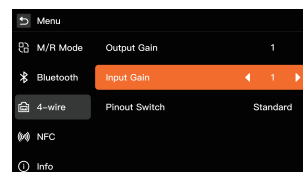

3. Select the [Pin-out Switch] icon to switch the pin-out mode of the base station's 4W interface according to the connected device's wiring standard:

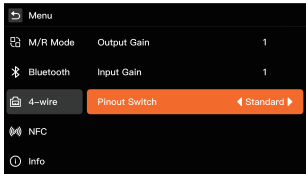

Standard Mode: Used when the base station is connected to similar systems (default).
 Crossover Mode: Used when the base station is connected to certain third-party systems (e.g., when input/output pin definitions are reversed).
 Note: If no sound or signal abnormality occurs, try switching the wire order mode to ensure the correct audio direction.

5.8 Information

In the [Information] menu, users can view the base station's basic information, system version, serial number, and perform operations such as language switching, firmware upgrade, and factory reset. This function is used for system maintenance, version management, and language adjustment.

5.8.1 Language Selection

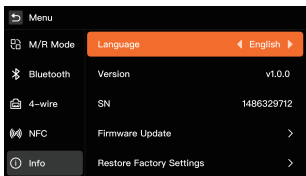

Used to switch the display language of the base station. The current version supports four languages: Chinese, English, Russian, and Japanese, which can be selected using the left/right direction keys.

5.8.2 Software Version Number

Displays the current base station firmware version (e.g., V1.0.0). When contacting after-sales support, please provide this version number to confirm system compatibility.

5.8.3 SN

Displays the base station's unique factory serial number, used for product registration, after-sales service, and system identification. Please keep it safe.

5.8.4 Firmware Upgrade

Enter the firmware upgrade page. Users can update the device firmware via the network. Do not power off or remove the storage device during the upgrade process.

5.8.5 Factory Reset

Restore the base station to factory default settings. After restoration, all pairing records, group configurations, and system settings will be cleared. Please proceed with caution.

6 Web Interface Settings

6.1 Logging into the Web Interface

The WiTalk Base can be accessed via a computer or mobile browser to reach the Web management interface for firmware upgrades, headset grouping, and status viewing. Two login methods are supported: Wireless login (suitable for quick access) and wired login (recommended, suitable for stable configuration and upgrades).

Method 1: Login via Base Station Hotspot (Suitable for Quick Access):

- Turn on the base station power and wait approximately 10 seconds. The base station will automatically enable its built-in WiFi hotspot.
- In the WiFi list on your phone or computer, find and connect to the base station hotspot: WiTalk_Base_XXXX (Default password: 12345678)
- Open a browser and enter in the address bar: http://192.168.2.1
- Enter the username and password on the login page to access the system.

Default login information:
 Username: admin

Password: 123456

Note: If accessing via a mobile phone, please stay within 3 meters of the base station for a more stable connection.

Method 2: Login via Ethernet Cable: (Recommended, suitable for stable configuration and upgrades)

- Use an Ethernet cable to directly connect the BASE to a computer, or connect both the BASE and the computer to the same local area network.
- Long press the base station menu button → select [WEB Control], and set the DHCP option to Off. (This page also allows you to view the base station's IP address and password)
- Set the computer's network segment to match the base station's network segment.

Connect the computer to the base station's RJ45 network interface via an Ethernet cable. Set the computer's network adapter IP address to [192.168.218.XXX]. The default IP address of the base station is [192.168.218.10], and the subnet mask is [255.255.255.0].

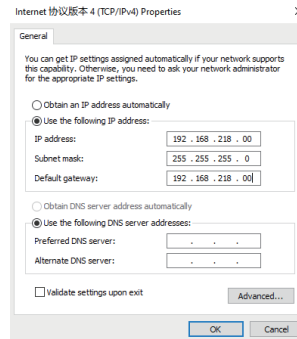

- Open a browser on the computer and enter the base station's IP address: http://192.168.218.10. Enter the username and password to log in and access the Web configuration interface. (Default username: admin, password: 123456)

6.2 Web Interface - Headset Settings

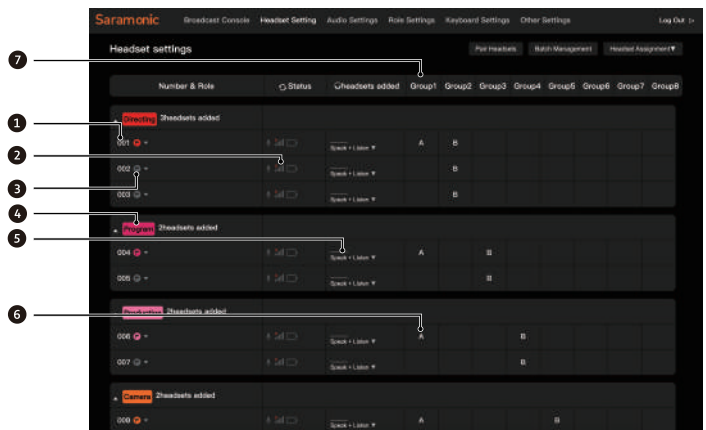

- Device ID
- Headset Status (White: Online; Gray: Offline)
- Leader Indicator
- Device Role
- Device Permissions
- Group Assigned to Device Button
- Available Groups

Note: Long press the role group column to adjust the order up or down.

6.3 Broadcast Console

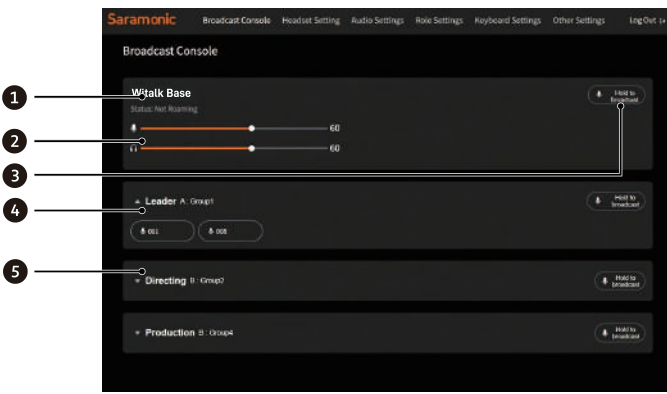

- 1 - Host Information Bar
Displays the current host name (e.g., "Base1") and cascade status, making it easy to distinguish between multiple host operations.
- 2 - Gain Control
Displays the current base station's microphone input volume and headphone monitoring volume, which can be manually adjusted.
- 3 - Group Broadcast
Press and hold the button to broadcast to all members within the group. All devices in the group are forced to listen-only mode and cannot speak. Upon release, the system returns to mute, and other devices in the group restore their original permissions. Suitable for directors or dispatchers issuing unified commands.
- 4 - Group Module
Click the triangle icon to expand or collapse the group content. Long press the blank area on the right side of a role group to rearrange the order of role groups.
- 5 - Devices in Group
Displays each headset's number and connection status in module card format (white: Online; Gray: Offline). Long press a device icon to initiate a 1-to-1 call. Other headsets are not affected during the call.

6.4 Device Button Grouping

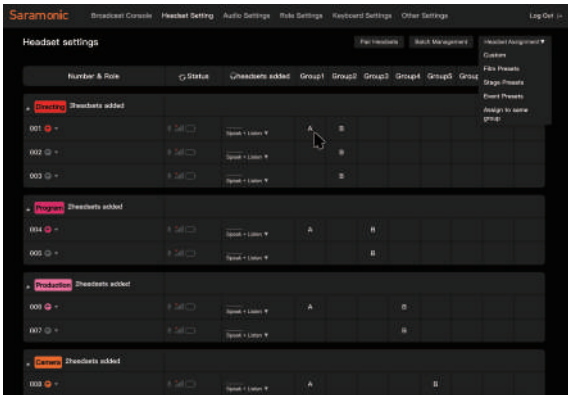

Button Grouping
In the group settings page, you can assign corresponding groups to the A/B talk buttons of each headset. Click the black square on the right side of the corresponding headset. Each click cycles through A/B/None, indicating that the headset has been assigned to the corresponding group "1" / "2" / "3", etc. The A and B buttons of the same headset can be assigned to different groups, for example:
A button assigned to Group 1
B button assigned to Group 2
Note:
The A/B buttons on the headset are used for quickly switching talk groups; You can monitor both A/B groups simultaneously, but you can only speak within the currently active group.

6.5 Deleting Headset Devices

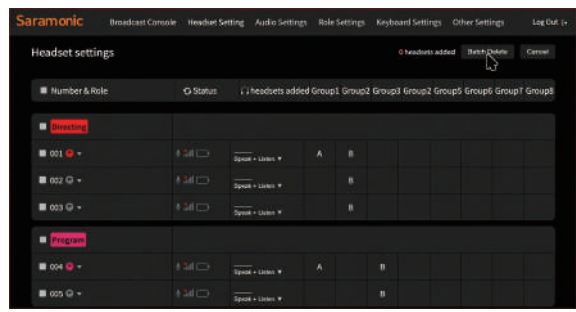

Delete Headset Devices
Click [Batch Manage] in the upper right corner to enter the device deletion interface. In this interface, you can manually select headset devices that are registered in the current base station system. After selecting the devices to be deleted, click the [Batch Delete] button in the upper right corner to confirm deletion. The system will automatically clear the pairing information of the selected headsets, and the devices will be restored to an unbound state.

Note: After deletion, the headsets can be re-paired. If a device is accidentally deleted, it can be re-bound through the re-pairing process.

6.6 Manual Configuration (Taking Custom Grouping as an Example)
Click [Headset Grouping] in the upper right corner of the headset settings page, select custom grouping to enter the configuration menu. In this interface, you can manually assign required roles to all devices supported by the base station (including offline devices).

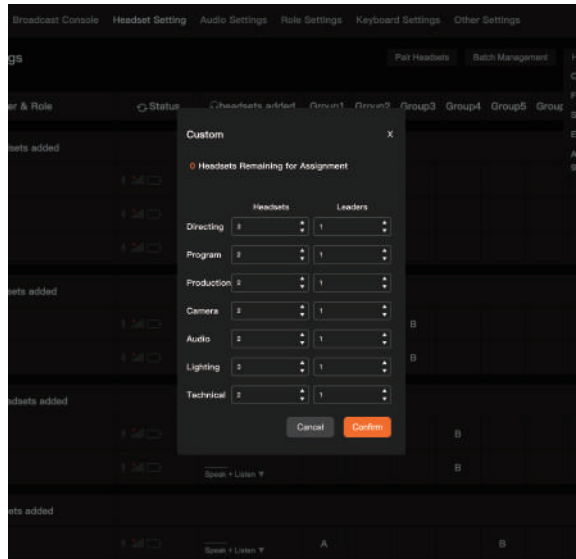

6.7 Role Management

Click [Role Settings] in the top menu bar to enter the role configuration interface. This page is used to define corresponding role attributes for different positions, including color identification, role name, talk mode, and default group. The system will automatically generate corresponding headset groups and talk modes on the [Group Settings] page based on the defined role templates.

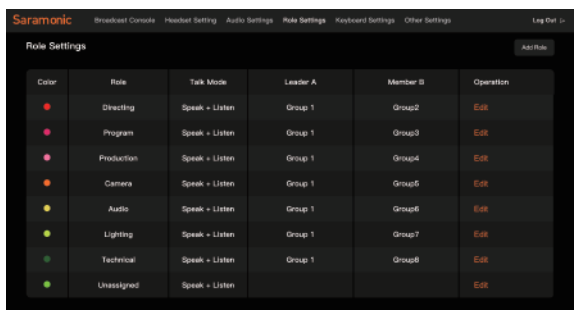

Click [Add Role] to individually modify each role group's status and talk mode. After modification, click [Save] to apply the changes.

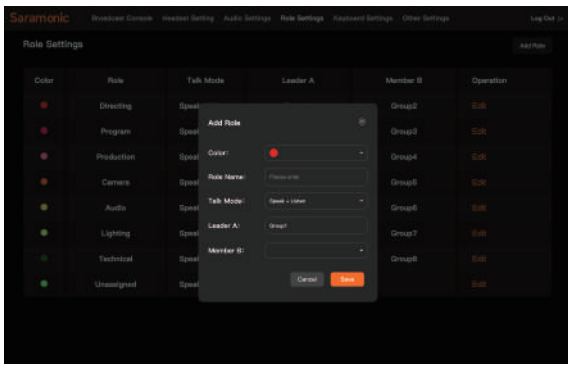

Note: You can restore the role configuration to its default state through factory reset.

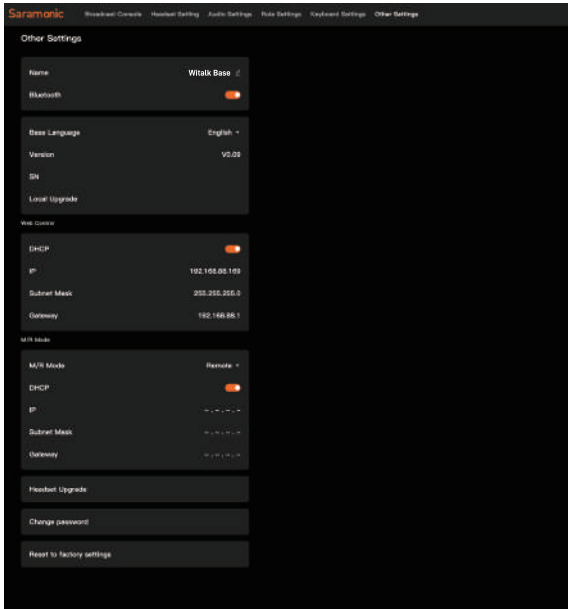

6.8 Audio Settings

This is the interface for configuring the audio input/output relationship between WiTalk Base and external devices (computers, mixers, walkie-talkies, etc.). Users can define the signal direction, gain level, and output assignment to different groups for each interface (UAC, 4-WIRE, 3.5mm) here.

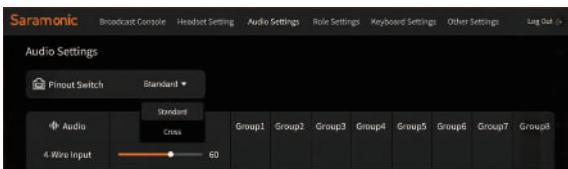

Audio Matrix Routing

Rows: Represent the "input/output channels" between the base station and external interfaces.

Columns: Represent the "talk groups" within the system.

Checkbox: Indicates routing the audio signal of this channel to the corresponding group.

For example:

If "4WIRE Input" is checked under "Group 2", it means all headsets in Group 2 can hear the signal from the 4-wire interface (e.g., walkie-talkie return audio);

If "UAC Output" is checked under "Group 5", it means the computer can receive the audio signal from Group 5 (e.g., live streaming audio).

6.9 Other Settings

Click [Other Settings] in the top menu bar to enter the base station's system and network comprehensive configuration interface.

This page is used to modify base station basic information, network parameters, language settings, and system upgrade options.

Web Language

Set the display language of the Web interface. Options include Chinese / English / Russian / Japanese.

Base Station Information

Displays and allows modification of the base station name, and supports enabling or disabling Bluetooth and NFC functions.

Base Station Version

Displays the base station software version number and serial number (SN); firmware updates can be performed via "Local Upgrade".

Master/Slave Settings

Set the operating mode of the base station (Master Device / Slave Device). When cascading multiple base stations, one of them must be designated as the "Master Device".

Headset Upgrade

Update the firmware of connected headset devices.

Change Account Password

Modify the Web login credentials.

Factory Reset

Reset all base station parameters to default values. All connected and registered headset device information will be completely cleared.

Usage Tips

- ① It is recommended to adjust DHCP与IP address parameters only when configuring the network or cascading devices;
- ② If the system encounters an abnormality, you can restore the default configuration through "Factory Reset";
- ③ Before performing a local upgrade, ensure the base station power supply is stable and use the official upgrade file provided;

7 WiTalk BASE App Settings Manual

7.1 APP Settings

7.1.1 Connecting to the Base Station

1. Download the "Saramonic System" app

2. Turn on your phone's Bluetooth, open the "Saramonic System" app. For first-time users, click [Audio Control] in the upper left corner to switch to [Talk Control], then click the [+] button to bind the WiTalk BASE device.

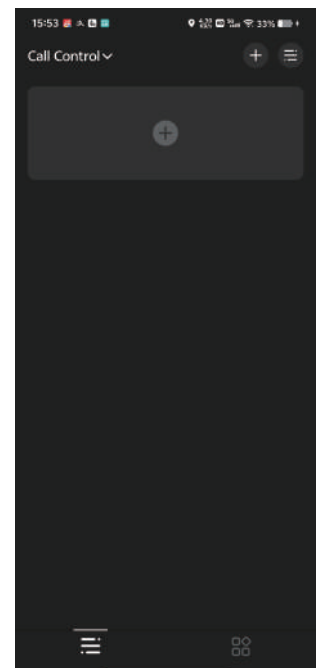
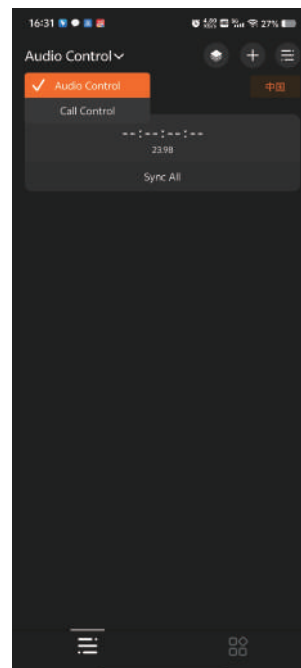

3. Select the device to bind based on the device Bluetooth name, and click Confirm to complete the device connection.

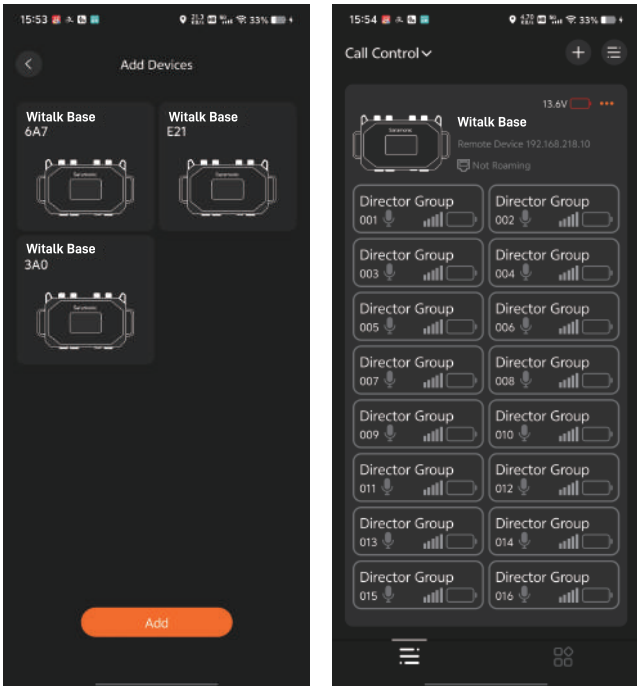

Click the console icon on the bottom right to enter the broadcast control console. Long press the corresponding "Push to Talk" button to broadcast to all role groups, a specific role group, or individual headsets through the WiTalk BASE device.

Function	Description
	Global Broadcast Long press the WiTalk Base's "Press and Hold to Talk" to broadcast to all groups
	Group Broadcast Long press a group "Press and Hold to Talk" to broadcast within that group
	Headset Broadcast Long press the headset ID to broadcast to a specific headset

7.2 Base Station Home Page

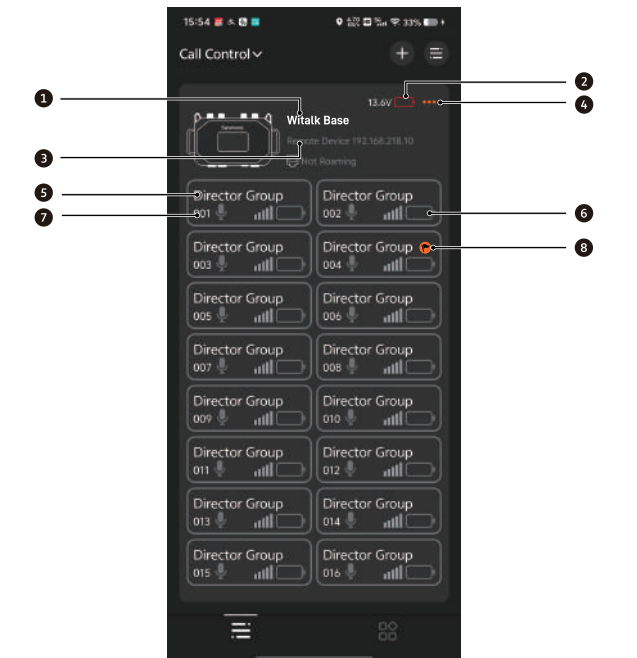

- 1. Base Station Name
- 2. Base Station Battery Level
- 3. Base Station Information
- 4. Base Station Settings
- 5. Device Role
- 6. Device Status
- 7. Device Number
- 8. Leader Indicator

7.3 Broadcast Control

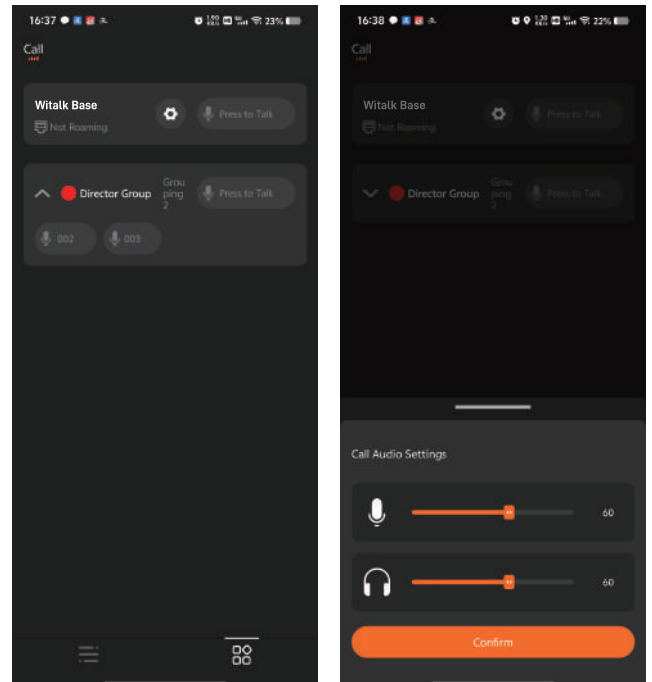
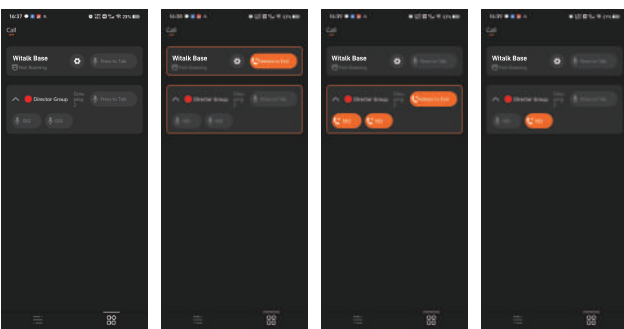

Click the settings button of the top device to set the input volume and listening volume for WiTalk Base calls.

7.4 Base Station Settings

Tap the base station area on the home page to enter the base station settings page, where you can add headsets, delete headsets, customize groups, and configure other settings.

7.4.1 Adding Headsets

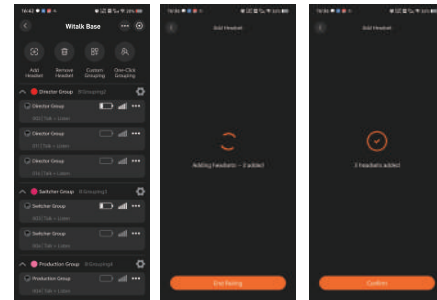

After tapping the [Add Headset] button, the base station will enter headset pairing mode. At this point, please also enable pairing mode on the headset to complete the connection between the base station and the headset.

Once the headset is successfully paired, tap [End Pairing] to exit pairing mode on the base station.

7.4.2 Delete Headset

Tap the [Delete Headset] button to open the headset deletion interface. Select the headset(s) to be deleted and tap the [Confirm] button to confirm the deletion.

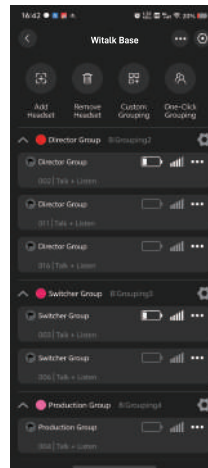
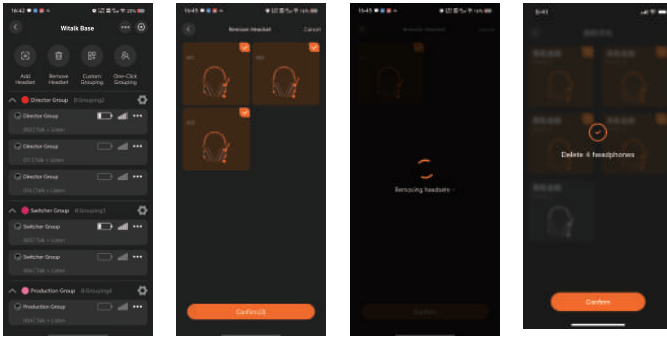

7.4.3 Custom Grouping

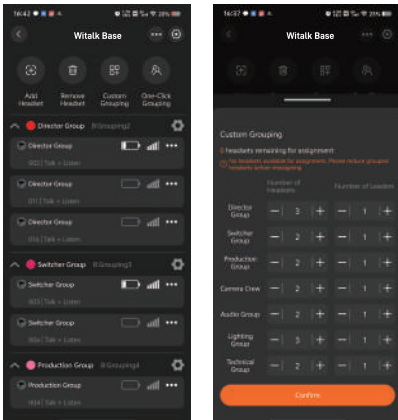

Tap [Custom Grouping]

to enter the group settings page, where you can assign roles to the 16 devices under the base station. You can manually set the number of headsets and leaders in each role group.

In each role group, the number of leaders must not exceed the number of headsets.

After completing the settings, tap the [Confirm] button. The system will save the role configuration and synchronize it to the base station and all paired headsets.

7.4.4 One-Tap Grouping

Tap [One-Tap Grouping] to quickly assign roles. After entering the preset menu, select the desired scenario preset to preview and manually adjust the number of headsets and leaders in each role group.

After entering the preset menu, select the desired scenario preset to preview and manually adjust the number of headsets and leaders in each role group.

Note: When selecting [One-Group Preset], all headsets will be automatically assigned to the Director group.

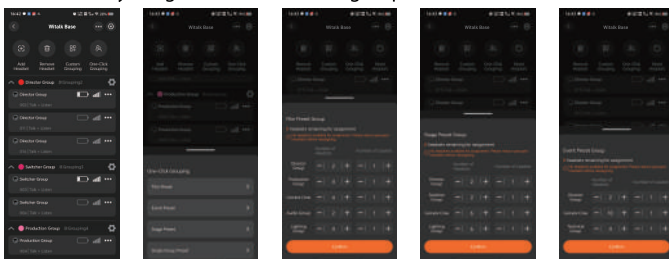

7.4.5 Resetting Headsets

Tap [Reset Headsets], and all headset settings in the base station will be restored to factory defaults.

7.4.6 Headset Settings

Tap the [...] button on the right side of the headset list to open the settings popup. Here you can rename the headset or change its assigned role group.

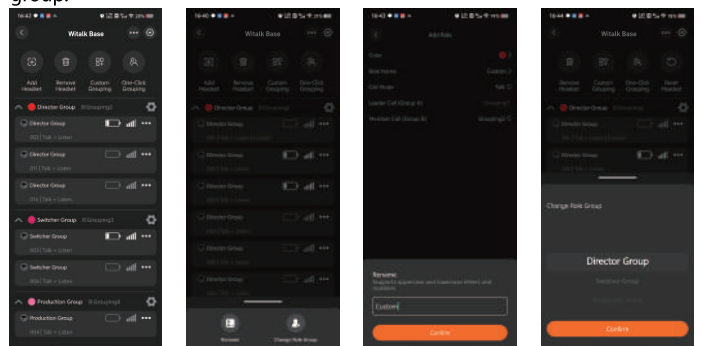

7.4.7 Role Group Settings

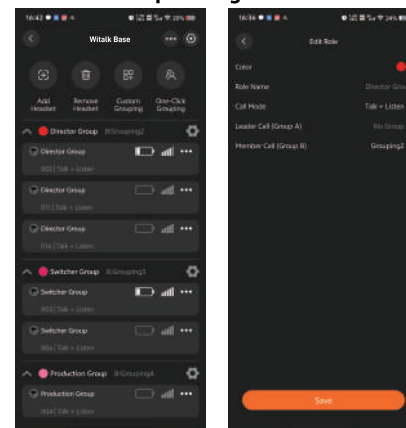

Tap the [Settings]

button on the right side of the role group to enter the role editing page.

On this page, you can adjust the color identifier of the role group, the talk mode of headsets within the group, and the talk group assignments for leaders and members.

Tap [Save], and the system will save the role group configuration and synchronize it to the base station and the headsets within the corresponding role group.

7.4.8 Adding a New Role Group

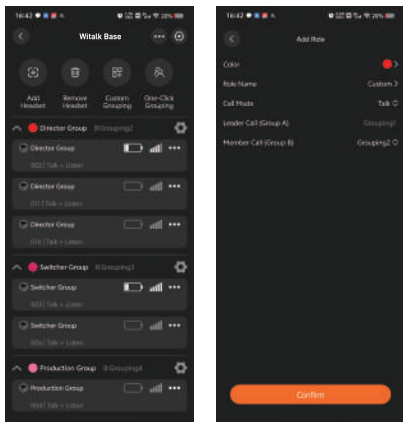

Tap [Add Role Group] to

create a custom role group.

On this page, you can set the color identifier, name, talk mode of headsets within the group, and the talk group assignments for leaders and members of the new role group.

Tap [Save], and the system will save the role group configuration and synchronize it to the base station.

7.4.9 WEB Control

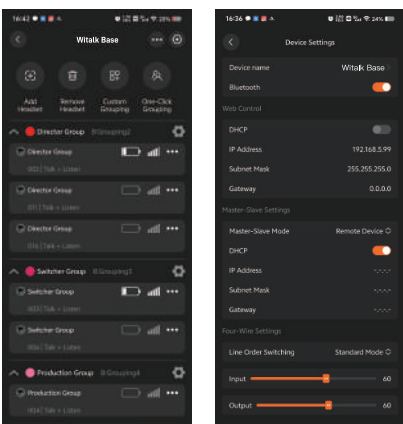

Tap the [...] button in

the upper right corner of the device details page to enter the device settings page.

On this interface, you can choose to automatically obtain or manually set the IP address for the base station's WEB page.

After enabling the DHCP switch, the system will automatically assign and generate the IP address for the base station's WEB page. After disabling DHCP, you can manually enter the **IP address, subnet mask, and gateway** information. Please configure according to your actual network environment.

7.4.10 Master/Slave Settings

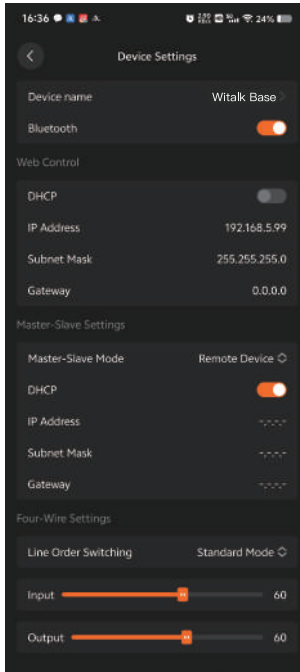

On the [Device Settings] interface,

you can change the base station's master/slave mode and network configuration.

On this interface, you can choose to automatically obtain or manually set the IP address of the base station.

After enabling the DHCP switch, the system will automatically assign and generate the base station's IP address, subnet mask, and gateway. After disabling DHCP, you can manually enter the IP address, subnet mask, and gateway information. Please configure according to your actual network environment.

7.4.11 Four-Wire Settings

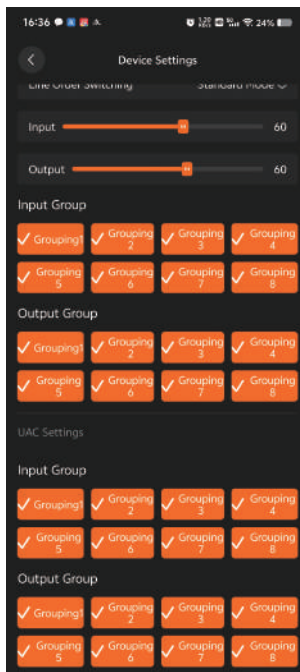

The four-wire interface

configuration can be viewed on the [Device Settings] page.

Users can select an appropriate volume level based on the input/output volume, and set the pin-out mode of the base station's four-wire interface to "Standard Mode" or "Cross Mode".

Based on actual requirements, select the talk groups for input/output and highlight the corresponding group buttons to route the audio signals of those groups to/from other devices cascaded via the four-wire interface.

7.4.12 UAC Settings

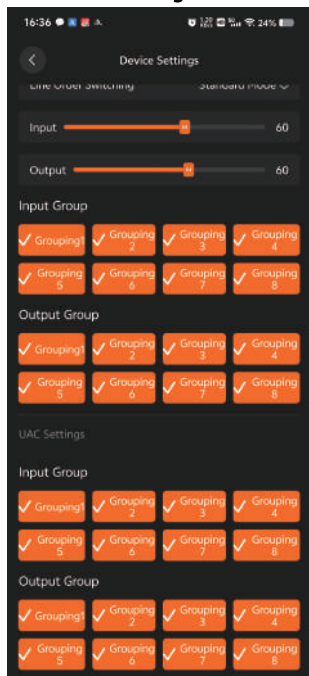

The UAC audio configuration can be viewed on the [Device Settings] page.

Based on actual requirements, select the talk groups for input/output and highlight the corresponding group buttons to route the audio signals of those groups to/from other devices cascaded via the UAC interface.

7.5 General Settings

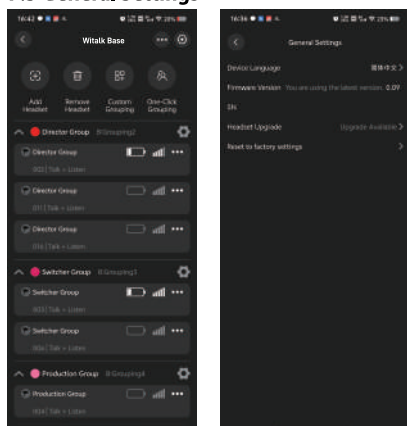

Tap the [Settings] button in the upper right corner of the device details page to enter the general settings page.

On this interface, you can view the current base station's display language, serial number, and firmware version.

7.5.1 Firmware Upgrade

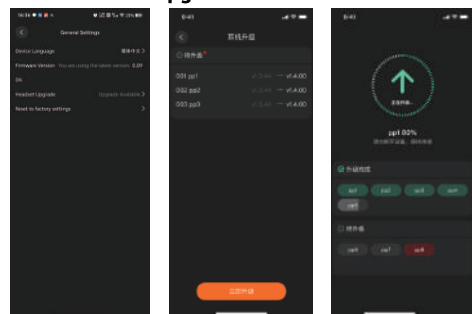

When a new firmware update is detected, you can tap the current firmware version on the [General Settings] page to view the upgrade information.

Tap the [Upgrade Now] button to start the base station firmware upgrade.

7.5.2 Headset Upgrade



On the [General Settings] page, tap [Headset Upgrade] to view the version information of the headsets connected to the current base station and the available upgrade versions.

Tap the [Upgrade Now] button to start the headset firmware upgrade.

7.5.3 Factory Reset

Tapping [Factory Reset] will display a popup indicating the base station that is about to be restored to factory settings. Tap [Confirm] to proceed with the factory reset.

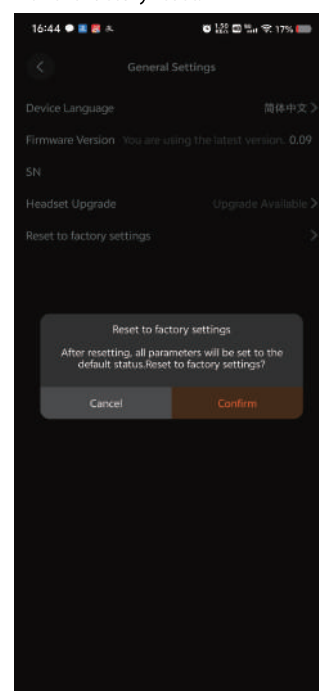

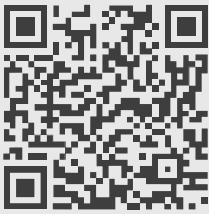

For better recording experience, the application **Saramonic System** is recommended.

为获得更好的录制体验，推荐使用枫笛 Saramonic 自主研发应用软件 **Saramonic System**。



Scan the QR Code to Access the Complete User Manual 扫码获取《用户手册》



Scan the QR Code to Access the Tutorial Videos 扫码观看操作教程

Shenzhen Jiayz Photo Industrial., Ltd
深圳市长丰影像器材有限公司

A16 Building, Intelligent Terminal Industrial Park of Silicon Valley
Power, Guanlan, Longhua District, Shenzhen, China
深圳市龙华区观澜街道大富工业区硅谷动力智能终端产业园A16栋

 400-613-1096  www.saramonic.com  support@saramonic.com